

# **PARTS MANUAL**

---

**E070-120Z  
(D098)**

**CUSTOMER EDITION**

---

***HYSTER***



**SECTIONS**

<b>1</b>	<b>FRAME</b>
<b>2</b>	<b>ELECTRICAL SYSTEM</b>
<b>3</b>	<b>DRIVE UNIT</b>
<b>4</b>	<b>STEERING SYSTEM</b>
<b>5</b>	<b>BRAKE/ACCELERATOR SYSTEM</b>
<b>6</b>	<b>HYDRAULIC SYSTEM</b>
<b>7</b>	<b>MAST-TWO STAGE LIMITED FREE-LIFT</b>
<b>8</b>	<b>MAST-THREE STAGE FULL FREE-LIFT</b>
<b>9</b>	<b>MAST-TWO STAGE FULL FREE-LIFT</b>
<b>10</b>	<b>OPTIONS</b>
<b>11</b>	<b>FIELD CONVERSION KITS</b>
<b>12</b>	<b>NUMERICAL INDEX</b>

This Parts Manual is divided into 12 major sections which are listed above. Quick reference to these sections can be made by placing the right thumb on the tab of the desired section, bending the book back and thumbing the pages to the corresponding tab.



**Thanks very much for your reading,  
Want to get more information,  
Please click here, Then get the complete  
manual**

**JustClickHere** 

**NOTE:**

**If there is no response to click on the link above,  
please download the PDF document first, and then  
click on it.**

**Have any questions please write to me:  
[admin@servicemanualperfect.com](mailto:admin@servicemanualperfect.com)**

**TABLE OF CONTENTS**

<b>DESCRIPTION</b>	<b>PAGE</b>
<b>A</b>	
ACCELERATOR .....	5-24
ACCELERATOR PEDAL MONOTROL .....	5-26
ACCUMULATOR .....	10-10
AUDIBLE ALARM KITS .....	11-2
AUXILIARY TUBE EXTENSION KIT .....	11-3
<b>B</b>	
BATTERY SPACER .....	1-8
BRAKE ASSEMBLY SEAT ACTUATED .....	5-12
BRAKE LINKAGE .....	5-16
BRAKE PRESSURE SWITCH .....	5-14
BRAKE SWITCH HARNESS .....	2-37
<b>C</b>	
CARRIAGE TWO STAGE FULL FREE-LIFT .....	9-22
CARRIAGE ASSEMBLY THREE STAGE FULL FREE-LIFT .....	8-34
TWO STAGE LIMITED FREE-LIFT .....	7-22
CONTACTOR POWER STEERING .....	2-12
CONTACTOR PANEL .....	2-10
CONTROL PANEL 36/48 VOLT .....	2-6
72/80 VOLT .....	2-8
CONTROL VALVE FIVE FUNCTION .....	6-26
FOUR FUNCTION .....	6-22
THREE FUNCTION .....	6-18
CONTROL VALVE CONVERSION KITS .....	11-2
COUNTERWEIGHT .....	1-30
<b>D</b>	
DC-DC CONVERTER 36/48 VOLT TO 12 VOLT - 70/80 VOLT TO 12 VOLT .....	10-2
DIRECTIONAL CONTROL CONVERSION .....	11-2
DRIVE AXLE .....	3-4
DRIVE LIGHTS 12 VOLT .....	10-4
DRIVE TIRE AND WHEEL .....	3-2
<b>E</b>	
EE/CRE INSTALLATION .....	1-6
ELECTRICAL CONVERSIONS .....	11-2
ELECTRICAL SYSTEM .....	2-2

**TABLE OF CONTENTS (continued)**

<b>DESCRIPTION</b>	<b>PAGE</b>
<b>F</b>	
FLOOR PLATES AND COVERS .....	1-2
FORKS	
CLASS III .....	1-36
CLASS IV .....	1-37
FREE LIFT	
THREE STAGE FULL FREE-LIFT .....	8-18
FREE LIFT CYLINDER	
THREE STAGE FULL FREE-LIFT .....	8-22
FREE-LIFT	
TWO STAGE FULL FREE-LIFT .....	9-14
FREE-LIFT CYLINDER	
TWO STAGE FULL FREE-LIFT .....	9-18
FULL SUSPENSION SEAT	
SHEET 1 OF 2 .....	1-18
SHEET 2 OF 2 .....	1-22
FULL SUSPENSION SWIVEL SEAT .....	1-24
<b>G</b>	
GEAR PUMP .....	4-10
<b>H</b>	
HEADER HOSE	
THREE STAGE FULL FREE-LIFT .....	8-26
THREE STAGE FULL FREE-LIFT - MAST HEIGHTS 5240 AND 5500 .....	8-30
TWO STAGE FULL FREE-LIFT - MAST HEIGHTS 2790MM UP TO 3290 AND 3050MM UP TO 3350 .....	9-30
TWO STAGE LIMITED FREE-LIFT - MAST HEIGHTS 3650MM, 3390MM, 3990 MM .....	7-14
TWO STAGE LIMITED FREE-LIFT - MAST HEIGHTS 2790MM AND 3050MM .....	7-18
HEADER HOSES	
TWO STAGE FULL FREE-LIFT - MAST HEIGHT 3390 MM, 3650 MM AND UP .....	9-26
HOOD .....	1-10
HYDRAULIC CONTROL	
HAND LEVERS .....	6-14
HYDRAULIC FILTER .....	6-10
HYDRAULIC MOTOR .....	6-8
HYDRAULIC PLUMBING	
CONTROL VALVE .....	6-12
HYDRAULIC PUMP	
29 CC .....	6-6
HYDRAULICS	
SINGLE PUMP AND MOTOR .....	6-2
<b>I</b>	
INNER MAST	
THREE STAGE FULL FREE-LIFT .....	8-8
TWO STAGE FULL FREE-LIFT .....	9-4
TWO STAGE LIMITED FREE-LIFT .....	7-4
INTEGRAL SIDE-SHIFT	
THREE STAGE FULL FREE-LIFT - E70-80Z, E100ZS .....	10-20

**TABLE OF CONTENTS (continued)**

<b>DESCRIPTION</b>	<b>PAGE</b>
THREE STAGE FULL FREE-LIFT - E100-120Z .....	10-22
TWO STAGE FULL FREE-LIFT - E70-80Z, E100ZS .....	10-16
TWO STAGE FULL FREE-LIFT - E100-120Z .....	10-18
TWO STAGE LIMITED FREE-LIFT - E100-120Z .....	10-12
TWO STAGE LIMITED FREE-LIFT - E70-80Z, E100ZS .....	10-14
<b>INTEGRAL SIDE-SHIFT CARRIAGE</b>	
THREE STAGE FULL FREE-LIFT - 1067 MM (42 IN.) CLASS III .....	10-36
THREE STAGE FULL FREE-LIFT - 1219 MM (48 IN.) CLASS III .....	10-38
THREE STAGE FULL FREE-LIFT - 1219 MM (48 IN.) CLASS IV .....	10-40
TWO STAGE FULL FREE-LIFT - 1067 MM (42 IN.) CLASS III .....	10-24
TWO STAGE FULL FREE-LIFT - 1219 MM (48 IN.) CLASS III .....	10-26
TWO STAGE FULL FREE-LIFT - 1219 MM (48 IN.) CLASS IV .....	10-28
TWO STAGE LIMITED FREE-LIFT - 1067 MM (42 IN.) CLASS III .....	10-30
TWO STAGE LIMITED FREE-LIFT - 1219 MM (48 IN.) CLASS III .....	10-32
TWO STAGE LIMITED FREE-LIFT - 1219 MM (48 IN.) CLASS IV .....	10-34
<b>INTERMEDIATE MAST</b>	
THREE STAGE FULL FREE-LIFT .....	8-6
<b>L</b>	
<b>LABELS</b> .....	1-32
<b>LED BACK-UP AND BRAKE LIGHTS</b> .....	10-6
<b>LIGHTS CONVERSION KITS</b> .....	11-2
<b>LINE CONTACTOR</b> .....	2-14
<b>LOAD BACKREST EXTENSION</b> .....	1-34
<b>M</b>	
<b>MAIN CYLINDER</b>	
THREE STAGE FULL FREE-LIFT .....	8-14
TWO STAGE LIMITED FREE-LIFT - E70-80Z, E100ZS .....	7-10
TWO STAGE LIMITED FREE-LIFT - E100-120Z .....	7-12
<b>MAIN LIFT</b>	
THREE STAGE FULL FREE-LIFT .....	8-10
TWO STAGE FULL FREE-LIFT .....	9-6
TWO STAGE LIMITED FREE-LIFT .....	7-6
<b>MAIN LIFT CYLINDER</b>	
TWO STAGE FULL FREE-LIFT .....	9-10
<b>MAST INSTALLATION</b> .....	6-30
<b>MASTER CYLINDER</b> .....	5-22
<b>N</b>	
<b>NON-SUSPENSION SEAT</b> .....	1-12
<b>O</b>	
<b>OUTER MAST</b>	
THREE STAGE FULL FREE-LIFT .....	8-2
TWO STAGE FULL FREE-LIFT .....	9-2
TWO STAGE LIMITED FREE-LIFT .....	7-2
<b>OVERHEAD GUARD</b>	
WITH CURVED LEG .....	1-28



**TABLE OF CONTENTS (continued)**

<b>DESCRIPTION</b>	<b>PAGE</b>
<b>P</b>	
PARK BRAKE	
LEVER ACTUATED .....	5-2
PARK BRAKE LINKAGE	
SEAT ACTUATED (→ S/N D098N01898D) .....	5-4
SEAT ACTUATED (S/N D098N01899D →) .....	5-8
<b>S</b>	
SEMI-SUSPENSION SEAT .....	1-16
SHIFT LEVER .....	4-16
STEER AXLE .....	4-2
STEER CYLINDER .....	4-6
STEER TIRE AND WHEEL .....	4-18
STEERING COLUMN .....	4-12
STEERING MOTOR AND PUMP .....	4-8
STEERING PUMP .....	4-14
STROBE LIGHT .....	10-8
SUPPLY AND RETURN .....	6-4
<b>T</b>	
TILT CONVERSION .....	11-2
TILT CYLINDER .....	6-32
TRACTION MOTOR .....	3-12
TRANSMISSION ASSEMBLY .....	3-8
<b>W</b>	
WIRE HARNESS	
DASH DISPLAY .....	2-28
LIGHTS (→ S/N D098N02036D) .....	2-30
LIGHTS (S/N D098N02037D →) .....	2-34
MAIN CONTROL - SHEET 1 OF 2 (→ S/N D098N01717C) .....	2-16
MAIN CONTROL - SHEET 2 OF 2 (→ S/N D098N01717C) .....	2-18
MAIN CONTROL - SHEET 1 OF 2 (S/N D098N01718C →) .....	2-20
MAIN CONTROL - SHEET 2 OF 2 (S/N D098N01718C →) .....	2-22
WIRE HARNESS 80 VOLT	
MAIN CONTROL - SHEET 1 OF 2 .....	2-24
MAIN CONTROL - SHEET 2 OF 2 .....	2-26

**ABBREVIATIONS QUICK REFERENCE SHEET**

Listed below are abbreviations used in parts manuals to denote the following expressions:

<b>TERM</b>	<b>DEFINITION</b>	<b>TERM</b>	<b>DEFINITION</b>
Amp	Amperes	FRE	Freezer Environment
AR	As Required	in.	inches
BDI	Battery Discharge Indicators	LPG	Liquefied Petroleum Gas
BWI	Brush Wear Indicator	MAP	Manifold Absolute Pressure
CE	Communicator End	mm	millimeters
CRE	Corrosive Environment	MSTS	Microprocessor Spark Timing System
D/B	Date Break	NPT	National Pipe Threads
dbA	Decibel "A" Scale	O/S	Oversize
DE	Drive End	PTO	Power Take Off
ECH	Empty Container Handler	RPM	Revolutions per Minute
ECH-3	Empty Container Handler - 3 High Stacking	S/N	Serial Number
ECH-4	Empty Container Handler - 4 High Stacking	TMM	Truck Management Module
ECH-5	Empty Container Handler - 5 High Stacking	UL Type D	Diesel-Powered Safety Rating
ECH-6	Empty Container Handler - 6 High Stacking	UL Type DS	Diesel-Powered Safety Rating
ECH-7	Empty Container Handler - 7 High Stacking	UL Type E	Battery-Powered Safety Rating
ECM	Electronic Control Module	UL Type EE	Battery-Powered Safety Rating
ECN	Engineering Change Notice	UL Type ES	Battery-Powered Safety Rating
EEPROM	Electrically Erasable Programmable Read Only Memory	UL Type G	Gasoline-Powered Safety Rating
EPA	US Environmental Protection Agency	UL Type GS	Gasoline-Powered Safety Rating
EPROM	Electrically Programmable Read Only Memory	UL Type LP	Gas-Powered Safety Rating
		UL Type LPS	LP Gas-Powered Safety Rating
		U/S	Undersize
		UL	Underwriters Laboratory
		V	Volts

## HOW TO USE THE ILLUSTRATED PARTS MANUAL

This parts manual describes and illustrates assemblies, subassemblies, and detail parts needed for service replacement.

The different constructions are indicated by keys and footnotes. The callouts correspond to descriptions found on the next page.

**HYSTER** UNIT CODE D001 NORTH AMERICA 06/2001

**TABLE OF CONTENTS**

DESCRIPTION	PAGE
AIR INTAKE AND FILTER DIESEL (⇒ D/B 11/98)	3-22
AIR INTAKE AND FILTER DIESEL (D/B 11/96 ⇒)	
AIR INTAKE AND FILTER GASOLINE AND LPG	
ALTERNATOR GASOLINE, LPG, AND DIESEL	
ALTERNATOR TYPES GS, LPS, AND DS	
AUXILIARY FUNCTION TUBE TWO AND THREE STAGE FULL F	

**SECTION 13 NUMERICAL INDEX**

PART NO.	PAGE NO.	ITEM NO.	PART NO.	PAGE NO.	ITEM NO.	PART NO.	PAGE NO.	ITEM NO.	PART NO.	PAGE NO.	ITEM NO.
142	3-4	19	10-13	25		11-27	29	12-31	12		
12445	3-32	19	10-17	6		11-31	25	16719	3-36	5	
	3-34	1	10-27	11		11-32	37	16751	3-16	27	
			11	11		8-4	29	16849	3-34	21	
			11	6	16485	8-4	45		3-38	20	
			12	11		8-4	45	16863	3-28	17	
			14	13		8-8	34	16865	3-6	18	
			12	6		9-7	9		4-27	41	
			3	17		9-7	19	16882	9-7	30	
			9	10		9-11	9		9-11	27	
			23	46		9-11	17		10-10	36	
			27	46		10-9	21		10-13	32	
			26	14		10-9	28		11-7	24	
			28	14		10-13	16		11-9	17	
			50	14		11-7	19				

**SECTIONS**

- 1
- 2
- 3
- 4
- 5 BRAKE/ACC
- 6
- 7 MAST-TWO STAG
- 8 MAST-THREE ST
- 9 MAST-TWO ST
- 10
- 11

**TRANSMISSION HOUSING** ⇒ S/N D001H-2628

KEY:  
A: Diesel  
B: Gasoline and LPG

ITEM	PART NO.	DESCRIPTION	QTY	
			A	B
1	2022547	Transmission	1	1
2	2023329	Transmission	1	1
3	2021670	Case	2	2
4	2023418	Bearing Cap	4	4
5	296429	Washer	4	4
6	293947	Bolt	1	1
7	2021390	Cover	2	2
8	1371656	Colter Pin	4	4
9	2021915	O-Ring	1	1
10	2021329	Plug	4	4
11	2021675	Housing	22	22
12	2021336	Pin	39	39
13	287860	Bolt	1	1
14	292682	Lockwasher	1	1
15	2021345	Hydraulic Pump	1	1
16	214364	⇒ Figure 5-3	8	8
17	296418	Gasket	1	1
18	2021388	Bolt	1	1
19	2021389	Washer	1	1
20	2021383	Temperature Switch	1	1
21	292515	Breather	9	9
22	136692	Dipstick	9	9
23	292527	Bolt	2	2
24	292531	Nut	3	3
25	292583	Bolt	3	2
26	293637	Capscrew	4	4
	296420	Lockwasher	4	4
	996403	Bolt	1	1
	996405	Washer	1	1
		Transmission Kit (Includes Item 7)	1	1
		Transmission Kit (Includes Item 14)	1	1

This Parts Manual is divided into 11 major sections which are listed above. Quick be made by placing the right thumb on the tab of the desired section, bending the pages to the corresponding tab.

© Copy Right Date HYSTER COMPANY See Service Manual for service procedures. 5-15

HP990004

## HOW TO FIND THE DESIRED PART NUMBER

### WHEN THE PART NUMBER AND THE NEXT HIGHER ASSEMBLY IS NOT KNOWN:

1. Determine the function and application of the part required. Turn to the Sections Page. Choose the general area of reference most likely to include the part.
2. Turn to the section you chose. Use the Section Table of Contents to determine the assembly which would normally contain the part required. Then locate the part on the assembly breakdown page.

### WHEN THE PART NUMBER IS NOT KNOWN AND THE NEXT HIGHER ASSEMBLY IS KNOWN:

3. Determine the assembly the required part is used on. Turn to the Table of Contents (Page i).
4. Locate the assembly the required part is used on and turn to the page indicated for that assembly. Then locate the part on the assembly breakdown page.

### WHEN THE PART NUMBER IS KNOWN:

5. Use the Numerical Index (Page 12-1) to find the part number. Turn to the page listed and locate the part as indicated by the item number.

### GENERAL:

The assembly breakdowns include part numbers, descriptions, quantities required, keys and footnotes to help in selecting correct parts.

6. Parts Supersession Information. Part numbers that have this history will be displayed in the parts list in the order that they were superseded (from oldest to newest). The superseded part numbers will be shown with a line through them.

Five periods in the PART NO. column (. . . . .) indicate that the part is either *Not Serviced Separately* or there is a reference to another figure. A figure reference is denoted by a pointing hand followed by a figure number in the DESCRIPTION column (☞ Figure 10)

7. Keys are used to show two or more similar assemblies, RH and LH assembly parts, etc. Select the appropriate key, "A", "B", "C", "D", or "E" and the corresponding quantity column to find the required parts. Two periods in the QTY column (..) indicate that the part is not used for that assembly.
8. Indented descriptions under the DESCRIPTION column are used to indicate assemblies and

subparts of assemblies. In the example on the previous page, *BEARING CAP* (Item 2) is a subpart of the major assembly *CASE*.

9. Quantities shown are for one assembly. The quantities of the subpart *BEARING CAP* are indicated as two and two. This means two per *CASE* assembly.
10. Serial number breaks identify the most current parts information and are shown as follows:
  - **S/N D001H2628**  
Indicates last serial number affected.
  - S/N D001H2629** →  
Indicates the first serial number affected.
  - S/N D001H1553** ↔ **S/N D001H3291**  
Indicates a range of serial numbers affected.

ECN numbers for pending serial numbers are shown to allow for the inclusion of the most current parts information and are identified as follows:

→ **S/N Pending Per ECN 63243**

Indicates a pending serial number for last unit affected.

**S/N Pending Per ECN 63243** →

Indicates a pending serial number for first unit affected.

Date breaks are used to indicate when a change occurred but a subsequent serial number break was not recorded. This is an arbitrary date usually based on the ECN release and are identified as follows:

→ **D/B 3/00**

Indicates that a change occurred sometime within that month for the item affected.

**D/B 3/00** →

Indicates that a change occurred sometime within that month for the item affected.

**D/B 3/00** ↔ **D/B 4/00**

Indicates a range of production dates of the item affected.

Contact your local dealer for Hyster lift trucks for serial number information for items with a ECN or a date break.

### ORDERING PARTS:

When ordering replacement parts, give the unit serial number, part number, name of part and quantity required.

For any further information on parts, service, or ordering, consult your local dealer for Hyster lift trucks.

## IDENTIFICATION OF TRUCK SERIAL NUMBERS

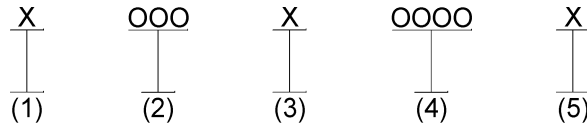

- (1) and (2) The first letter and three numbers indicate the truck unit code.
- (3) The second letter indicates the plant of manufacture.
- (4) The four or five digit number indicates the production sequence number of the truck.
- (5) The final letter indicates the year of manufacture starting with "A" in 1957, 1980, and 2003. The letters "I", "O", and "Q" will not be used.

For pending serial numbers contact your local dealer for Hyster lift trucks.

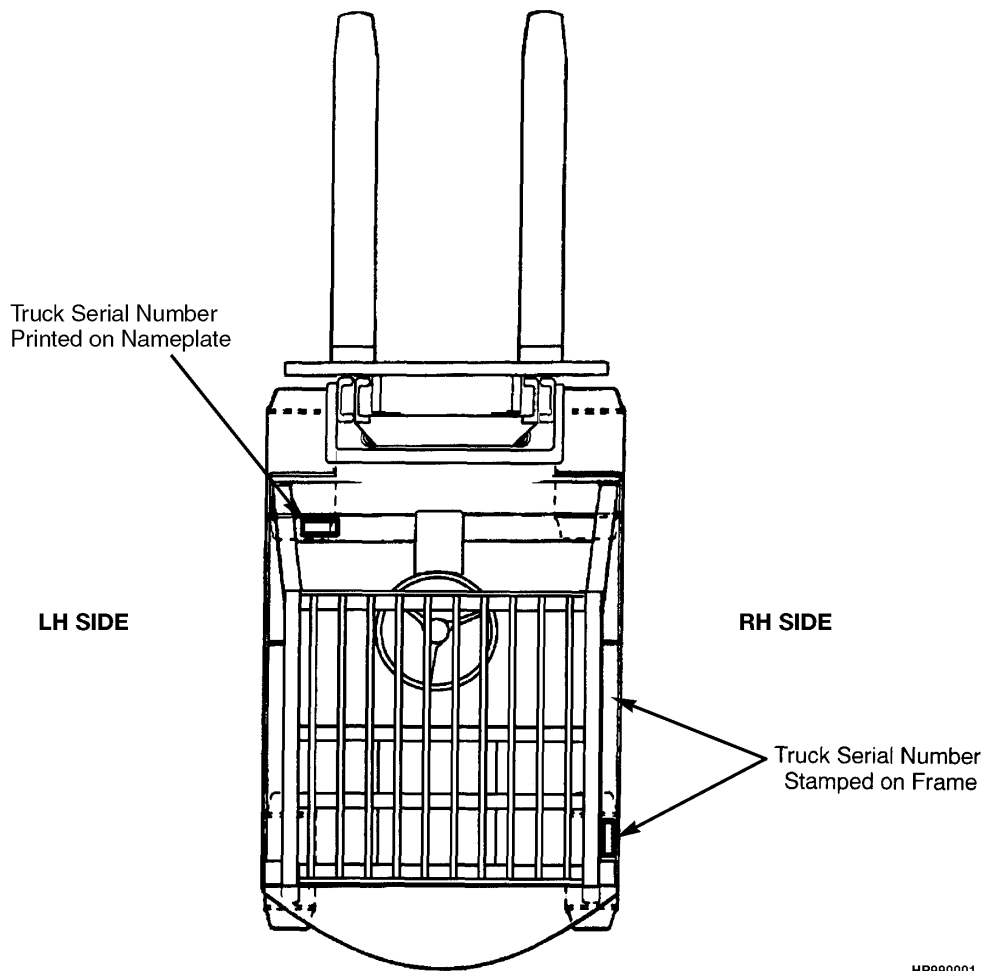

HP990001

Parts referred to in this book as right or left hand parts are in accordance with the illustration above.

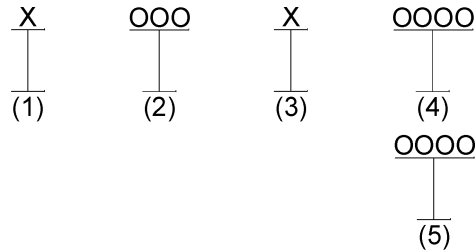
**IDENTIFICATION OF MAST SERIAL NUMBERS**

- (1) and (2) The first letter and number indicates the mast unit code.
- (3) The second letter indicates the plant of manufacture.
- (4) The four or five digit number indicates the production sequence number of the mast.
- (5) Carriage travel in millimeters stamped just below the serial number.

Mast Group identification consists of mast unit code (1) and (2) plus carriage travel (5).

For pending production sequence numbers contact your local dealer for Hyster lift trucks.

**LIFT EQUIPMENT IDENTIFICATION**

1. Fork part number, capacity rating, plant code letter, and date of manufacture are stamped approximately six inches below the top of most forks.
2. The carriage group number is stamped on the right hand side of the top crossmember (pin type) or on the back of the right hand end of the bottom crossmember (hook type). A date code has two letters in line with or below the carriage group number.
3. The mast identification number has a unit code, a letter indicating the plant of manufacture, and a serial number. Underneath the production sequence number is a four digit number that indicates the carriage travel in millimeters.
4. Tilt and lift cylinder group numbers are stamped on the cylinder shell.

Always refer to the group, serial, or part number when ordering service parts.

Modification of masts and carriages by SPED (Special Products Engineering Department) are identified by a model prefix code beginning with the letter "S". contact your dealer for Hyster lift trucks for information on these assemblies.

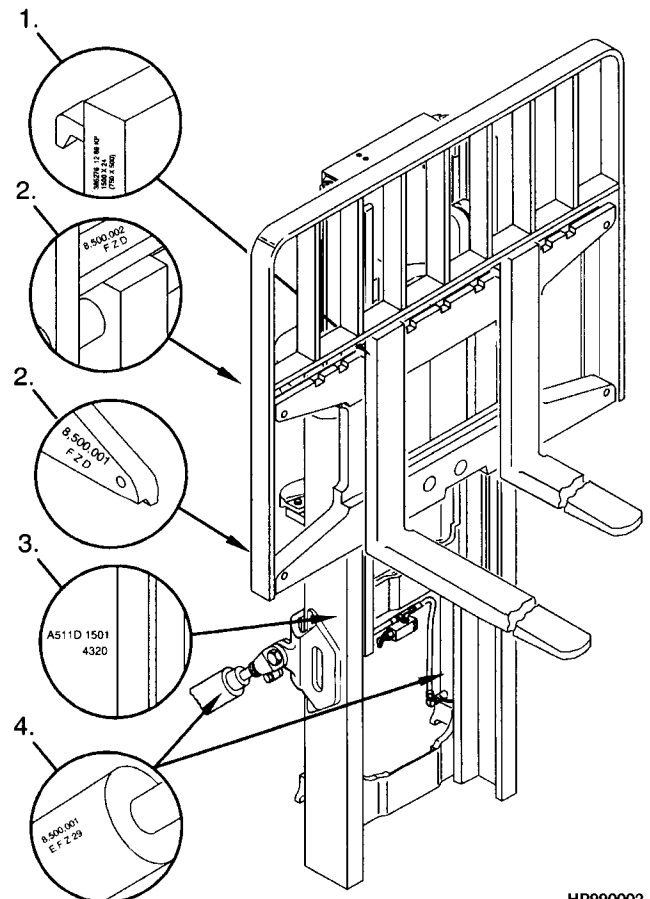

HP990002

## IDENTIFICATION OF ATTACHMENT AND SIDE-SHIFT CARRIAGE SERIAL NUMBERS

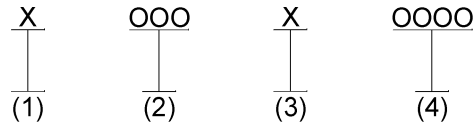

(1) and (2) The first letter and three numbers indicate the attachment unit code.

(3) The second letter indicates the plant of manufacture.

(4) The four or five digit number indicates the production sequence number.

For pending production sequence numbers contact your local dealer for Hyster lift trucks.

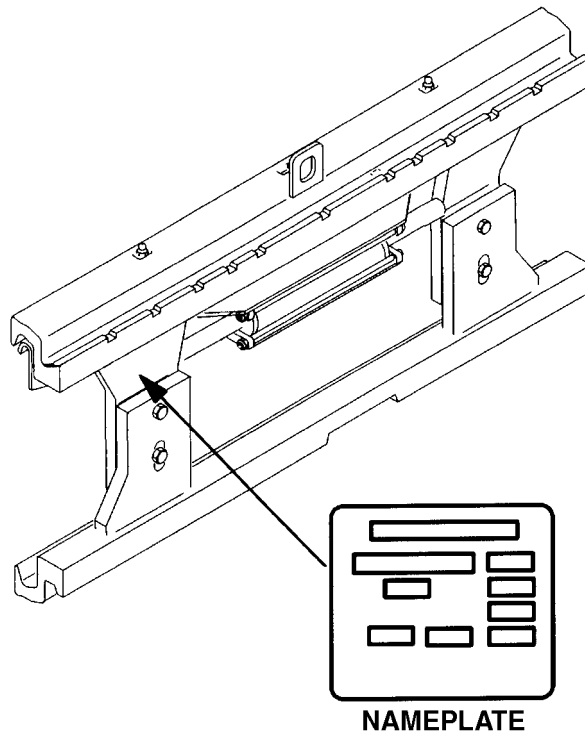

HP990003

Side-shift carriages and attachments have nameplates. Use the serial number found on the nameplate to identify the attachment.

Always refer to the group, serial, or part number when ordering service parts.

Modifications of attachments and side-shift carriages by SPED (Special Products Engineering Department) are identified by a model prefix code beginning with the letter "S". Contact your dealer for Hyster lift trucks for information on these assemblies.

**PUBLICATIONS**

Every new lift truck is provided with an OPERATING MANUAL. This manual has information that the operator must know for inspection and operation of the lift truck.

SERVICE MAINTENANCE MANUALS, which provide service and overhaul procedures, and PARTS

MANUALS with complete replacement part identification, are available at a nominal fee from your Hyster dealer to assist users in effectively maintaining Hyster lift trucks in a safe, useful condition. See the list below for information on ordering specific publications for this model lift truck.

---

<b>PUBLICATION</b>	<b>HYSTER PART NUMBER</b>
Operating Manual.....	1596580
Service Manual (Complete).....	1596596
Parts Manual.....	1596589





**1**

**FRAME**



**SECTION 1  
FRAME**

<b>DESCRIPTION</b>	<b>PAGE</b>
BATTERY SPACER .....	1-8
COUNTERWEIGHT .....	1-30
EE/CRE INSTALLATION .....	1-6
FLOOR PLATES AND COVERS .....	1-2
FORKS	
CLASS III .....	1-36
CLASS IV .....	1-37
FULL SUSPENSION SEAT	
SHEET 1 OF 2 .....	1-18
SHEET 2 OF 2 .....	1-22
FULL SUSPENSION SWIVEL SEAT .....	1-24
HOOD .....	1-10
LABELS .....	1-32
LOAD BACKREST EXTENSION .....	1-34
NON-SUSPENSION SEAT .....	1-12
OVERHEAD GUARD	
WITH CURVED LEG .....	1-28
SEMI-SUSPENSION SEAT .....	1-16